

H38963 -UN-13OCT88

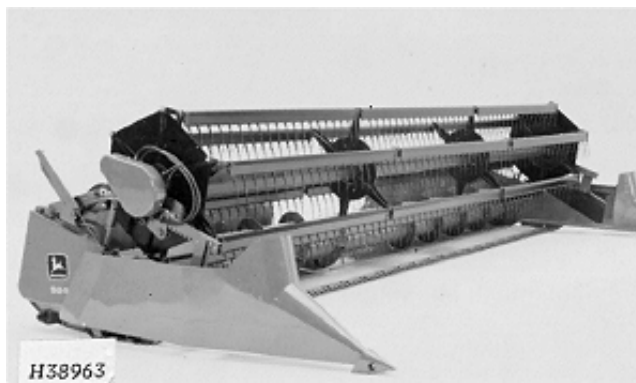

JOHN DEERE 924 FLEX CUTTERBAR PLATFORM WITH PICKUP REEL

(SPECIFICATIONS AND DESIGN SUBJECT TO CHANGE WITHOUT NOTICE)

DATE OF MANUFACTURE

MODEL NO.	TYPE	DATE
913	RIGID	(1988-1990)
913	FLEX	(1988-)
915	FLEX	(1988-)
915	RIGID	(1988-1991)
918	FLEX	(1988-)
918	RIGID	(1988-1991)
920	RIGID, FLEX	(1988-)
922	RIGID, FLEX	(1988-)
924	RIGID, FLEX	(1988-1989)
925	RIGID, FLEX	(1990-)
925	FLEX ARGENTINA	(1998-)
930	RIGID	(1988-)
930	FLEX	(1989-)
930	RIGID RICE	(1995-)
930	FLEX ARGENTINA	(1996-)

SERIAL NUMBER PLATE

USE ALL NUMBERS, LETTERS, AND SPACES SHOWN ON THE SERIAL NUMBER PLATE IN WARRANTY CORRESPONDENCE.

THE SERIAL NUMBER PLATE IS LOCATED ON THE LEFT-HAND SIDE OF THE FRAME.

*EXAMPLE: H00920F625001
920 PLATFORM*

(FIRST LINE) H0 - FACTORY (HARVESTER WORKS)
 0920 - PLATFORM MODEL
 F - CONFIGURATION/MODEL SUFFIX
 625001 - PLATFORM SEQUENCE NUMBER (SERIAL NUMBER)
(SECOND LINE) PLATFORM - PRODUCT TYPE

SERIAL NUMBER LISTING INFORMATION

SERIAL NUMBER INFORMATION IS LISTED TO SHOW ON WHICH MACHINES EACH PART CAN BE USED, FOR EXAMPLE:

- THE PART CAN BE USED ON ALL MACHINES.
000000- THE PART CAN BE USED ON ALL MACHINES BEGINNING WITH THE SERIAL NUMBER LISTED.
-000000 THE PART CAN BE USED ON ALL MACHINES UP TO AND INCLUDING THE SERIAL NUMBER LISTED.
000000-000000 THE PART CAN BE USED ON ALL MACHINES BETWEEN AND INCLUDING THE SERIAL NUMBERS LISTED.

WHEN XXXXXX'S ARE LISTED IN PLACE OF A SERIAL NUMBER, A SERIAL NUMBER CHANGE WAS MADE BUT THE EXACT SERIAL NUMBER WAS NOT AVAILABLE WHEN THE CATALOG WAS PRODUCED.

*COPYRIGHT (C) 2000. DEERE & COMPANY. MOLINE, ILLINOIS
ALL RIGHTS RESERVED*

DIRECTION ARROW

ARROWS ARE USED WITH ILLUSTRATIONS TO INDICATE THE FRONT OF THE UNIT. "RIGHT-HAND" AND "LEFT-HAND" SIDES ARE DETERMINED BY FACING IN THE DIRECTION OF MACHINE FORWARD TRAVEL.

BOX-ENCLOSED ILLUSTRATIONS

A KEY NUMBER, SHOWN IN THE PARTS LIST, IS ASSIGNED TO A BOX ENCLOSING ALL PARTS SOLD AS A SERVICE ASSEMBLY. A BOX NOT KEYED INCLUDES NON-CURRENT PARTS.

KITS

KIT INFORMATION WILL BE FOUND IMMEDIATELY FOLLOWING THE STORY IN WHICH IT IS USED. THE ILLUSTRATION IS REPEATED WITH ONLY THE KIT PARTS CALLED OUT AND WITH ALL OTHER PARTS SHOWN IN PHANTOM.

JDM REMANUFACTURED COMPONENTS

THE SERVICE PARTS LISTED IN THIS CATALOG ARE INTENDED FOR THE REPAIR OF ORIGINAL EQUIPMENT COMPONENTS. ALTHOUGH MOST SERVICE PARTS MAY BE USED TO REPAIR REMANUFACTURED COMPONENTS, THE REMANUFACTURED DESIGN MAY CHANGE PARTS SUFFICIENTLY SO THAT SERVICE PARTS ARE INADEQUATE OR NOT USABLE.

BOLT AND CAP SCREW STRENGTH IDENTIFICATION

BOLTS AND CAP SCREWS REQUIRED TO HAVE HIGH-STRENGTH QUALITIES EQUIVALENT TO SAE GRADE 8 ARE IDENTIFIED THROUGHOUT THIS CATALOG BY THE DESCRIPTION HS SAE 8. ALL STANDARD BOLTS AND CAP SCREWS ARE SAE GRADE 5 OR LOWER. BOLTS AND CAP SCREWS REQUIRED TO HAVE HIGH-STRENGTH QUALITIES EQUIVALENT TO PROPERTY CLASS 10.9 ARE IDENTIFIED THROUGHOUT THIS CATALOG BY THE DESCRIPTION HS 10.9. ALL STANDARD BOLTS AND CAP SCREWS ARE PROPERTY CLASS 8.8 OR LOWER.

SI UNITS OF MEASURE

METRIC DIMENSIONS ARE GIVEN, WHERE APPLICABLE, THROUGHOUT THIS PARTS CATALOG.

TRADEMARKS

THROUGHOUT THIS PARTS CATALOG, YOU WILL FIND THE FOLLOWING DEERE & COMPANY TRADEMARKS:

DIAL-A-SPEED™
DIAL-A-MATIC™
HARVESTRAK™

POSI-TORQ™
TORQ-GARD SUPREME®
QUIK-TATCH™

CHANGE INDICATOR LINE

CHANGES AFFECTING THE ORDERING OF PARTS ARE IDENTIFIED BY VERTICAL LINES MARKED IN THE LEFT-HAND MARGIN OF REVISED PARTS LISTING IMAGES. A LINE IS ALSO AT THE LEFT-HAND EDGE OF THE SAME PART NUMBER IN THE NUMERICAL INDEX TO SHOW THE LOCATION OF REVISED INFORMATION.

FUNCTION CODE

(EXAMPLE - FC: 5000)

FUNCTION CODES ARE LOCATED ON EACH PAGE IN THE UPPER RIGHT-HAND CORNER. THE CODE LISTED IS A GROUPING CODE THAT CAN BE USED FOR WARRANTIES AND FOR DTAC TO IDENTIFY CERTAIN AREAS.

COMPLETE GOODS LISTINGS

COMPLETE GOODS ARE IN BOLD FACE TYPE. ORDER SEPARATELY. DO NOT INCLUDE ON REPLACEMENT PARTS ORDER.

SECTION INDEX

SECTION 05 - GENERAL INFORMATION

SECTION 10 - REEL

SECTION 15 - FRAME, SHEETS, DIVIDERS, SKID PLATES AND HEADER HEIGHT CONTROL

SECTION 20 - KNIFE, CUTTERBAR AND DRIVES

SECTION 25 - AUGER AND DRIVE

SECTION 30 - HYDRAULICS

SECTION 35 - IDLERS, TIGHTENERS AND SHIELDS

SECTION 40 - BELTS, CHAINS, SHEAVES, SPROCKETS AND DECALS

SECTION 45 - NUMERICAL INDEX

**Thanks very much for your reading,
Want to get more information,
Please click here, Then get the complete
manual**

JustClickHere 

NOTE:

**If there is no response to click on the link above,
please download the PDF document first, and then
click on it.**

**Have any questions please write to me:
admin@servicemanualperfect.com**

ALPHABETICAL INDEX

GRID		PAGE	GRID		PAGE
	A				
C18	ADAPTER KIT, FLEX PLATFORM TILT.....	15 - 16	H11	AUGER HUB (635101-655300)	25 - 8
A17	ARM, PICKUP REEL (-645300)	10 - 2	H13	AUGER HUB (655301-13MAY96)	25 - 10
B22	ARM, REEL (-655300)	10 - 32	H17	AUGER SHAFTS (-655300)	25 - 14
B24	ARM, REEL (655301-)	10 - 35	H19	AUGER SHAFTS (655301-)	25 - 16
B17	ARM, SLAT REEL 913, 915, 918.....	10 - 26	H21	AUGER SHIELDS (-655300)	25 - 18
B18	ARM, SLAT REEL 920, 922, 924, 925, 930 (-655300)	10 - 28	H23	AUGER SHIELDS (655301-)	25 - 20
B20	ARM, SLAT REEL 920, 922, 925, 930 (655301-)	10 - 30	H21	AUGER SPROCKET (-655300)	25 - 18
H11	AUGER AND SHAFT (635101-655300)	25 - 8	H23	AUGER SPROCKET (655301-)	25 - 20
H13	AUGER AND SHAFT (655301-13MAY96)	25 - 10	H21	AUGER SUPPORT (-655300)	25 - 18
H17	AUGER BEARINGS (-655300)	25 - 14	H23	AUGER SUPPORT (655301-)	25 - 20
H19	AUGER BEARINGS (655301-)	25 - 16	H15	AUGER, AND SHAFT (655301-)	25 - 12
H21	AUGER BRACKETS (-655300)	25 - 18	H15	AUGER, CROSS, HUB (655301-)	25 - 12
H23	AUGER BRACKETS (655301-)	25 - 20		B	
H11	AUGER COVER (635101-655300)	25 - 8	H17	BEARINGS, AUGER (-655300)	25 - 14
H13	AUGER COVER (655301-13MAY96)	25 - 10	H19	BEARINGS, AUGER (655301-)	25 - 16
H17	AUGER CRANK (-655300)	25 - 14	H7	BEARINGS, SHAFTS, FINGERS, CROSS AUGER (-635100)	25 - 4
H19	AUGER CRANK (655301-)	25 - 16	H9	BEARINGS, SHAFTS, FINGERS, CROSS AUGER (-635100)	25 - 6
I1	AUGER DRIVE (-635100)	25 - 22	K14	BELT, DRIVE, L.H. SIDE.....	40 - 1
I3	AUGER DRIVE (-635100)	25 - 24	F7	BOLTED KNIFE (-655300)	20 - 4
I5	AUGER DRIVE (635101-655300)	25 - 26	F11	BOLTED KNIFE (655301-)	20 - 8
I7	AUGER DRIVE (655301-665300)	25 - 28	F15	BOLTED KNIFE - DURA-CUT.....	20 - 12
I9	AUGER DRIVE (665301-)	25 - 30	F13	BOLTED KNIFE - DURA-LITE.....	20 - 10
I11	AUGER DRIVE (SIDEHILL) (-640500) 6600/6620 COMBINES	25 - 32	F5	BOLTED KNIFE AND MOUNTINGS (-655300)	20 - 2
I13	AUGER DRIVE (SIDEHILL/CONTOUR MASTER) (645301-655300) 9500SH COMBINES.....	25 - 34	F9	BOLTED KNIFE AND MOUNTINGS (655301-)	20 - 6
I15	AUGER DRIVE (SIDEHILL/CONTOUR MASTER) (655301-665300) (9500SH COMBINES)	25 - 36	E7	BOX, SENSING FLEX (-655300)	15 - 54
I17	AUGER DRIVE (SIDEHILL/CONTOUR MASTER) (655301-665300) (9500SH COMBINES)	25 - 38	E8	BOX, SENSING FLEX (655301-)	15 - 55
I21	AUGER DRIVE (SIDEHILL/CONTOUR MASTER) (665301-)18,20,22,25,30'(9500SH)	25 - 42	F17	BRACKET, KNIFE STORAGE	20 - 14
I23	AUGER DRIVE (SIDEHILL/CONTOUR MASTER) (665301-)18,20,22,25,30'(9500SH)	25 - 44	H21	BRACKETS, AUGER (-655300)	25 - 18
I19	AUGER DRIVE (SIDEHILL/CONTOUR MASTER) (665401-) 15 FT (9500SH COMBINES)	25 - 40	H23	BRACKETS, AUGER (655301-)	25 - 20
H17	AUGER FINGERS (-655300)	25 - 14		C	
H19	AUGER FINGERS (655301-)	25 - 16	C11	CABLE, SAFETY (SIDEHILL/CONTOUR MASTER) (660301-)	15 - 8
H5	AUGER FLIGHT EXTENSIONS (-655300)	25 - 1	G1	CASE, KNIFE DRIVE.....	20 - 22
H6	AUGER FLIGHT EXTENSIONS (655301-)	25 - 2	F21	CASE, KNIFE DRIVE (-655300)	20 - 18
			F23	CASE, KNIFE DRIVE (655301-)	20 - 20

ALPHABETICAL INDEX - CONTINUED

GRID		PAGE	GRID		PAGE
K15	CHAINS, DRIVE, R.H. SIDE	40 - 2	K6	COUPLER AND HOSE CONVERSION	
I11	CLUTCH, AUGER DRIVE (SIDEHILL)			20 SERIES COMBINES (600001-622500)	30 - 30
	(-640500) 6600/6620 COMBINES	25 - 32	H11	COVER, AUGER	
I13	CLUTCH, AUGER DRIVE (SIDEHILL/CONTOUR			(635101-655300)	25 - 8
	MASTER(645301-655300) 9500SH COMBINES	25 - 34	H13	COVER, AUGER	
I15	CLUTCH, AUGER DRIVE (SIDEHILL/CONTOUR			(655301-13MAY96)	25 - 10
	MASTER)(655301-665300)(9500SH COMBINE)	25 - 36	H15	COVER, CROSS AUGER	
I17	CLUTCH, AUGER DRIVE (SIDEHILL/CONTOUR			(655301-)	25 - 12
	MASTER)(655301-665300)(9500SH COMBINE)	25 - 38	H17	CRANK, AUGER	
I21	CLUTCH, AUGER DRIVE (SIDEHILL/CONTOUR			(-655300)	25 - 14
	MASTER)(665301-)18,20,22,25,30'	25 - 42	H19	CRANK, AUGER	
I23	CLUTCH, AUGER DRIVE (SIDEHILL/CONTOUR			(655301-)	25 - 16
	MASTER)(665301-)18,20,22,25,30'	25 - 44	H15	CROSS AUGER COVER	
I19	CLUTCH, AUGER DRIVE (SIDEHILL/CONTOUR			(655301-)	25 - 12
	MASTER)(665401-) 15 FT (9500SH)	25 - 40	H7	CROSS AUGER, BEARINGS, SHAFTS, FINGERS	
I1	CLUTCH, SLIP, AUGER DRIVE			(-635100)	25 - 4
	(-635100)	25 - 22	H9	CROSS AUGER, BEARINGS, SHAFTS, FINGERS	
I3	CLUTCH, SLIP, AUGER DRIVE			(-635100)	25 - 6
	(-635100)	25 - 24	G3	CUTTERBAR DRIVE	
I5	CLUTCH, SLIP, AUGER DRIVE			(-655300)	20 - 24
	(635101-655300)	25 - 26	G5	CUTTERBAR DRIVE	
I7	CLUTCH, SLIP, AUGER DRIVE			(655301-)	20 - 26
	(655301-665300)	25 - 28	G9	CUTTERBAR DRIVE (SIDEHILL)	
I9	CLUTCH, SLIP, AUGER DRIVE			(-645300) (9500SH COMBINES)	20 - 30
	(665301-)	25 - 30	G7	CUTTERBAR DRIVE - EUROPEAN	20 - 28
I15	CONTOUR MASTER AUGER DRIVE	25 - 36	G21	CUTTERBAR DRIVE SUPPORT SPRING	
I17	CONTOUR MASTER AUGER DRIVE	25 - 38		FLEX (-655300)	20 - 43
I19	CONTOUR MASTER AUGER DRIVE		G22	CUTTERBAR DRIVE SUPPORT SPRING	
	(15 FT.) (665401-)	25 - 40		FLEX (655301-)	20 - 44
I21	CONTOUR MASTER AUGER DRIVE		G11	CUTTERBAR DRIVE, L.H. (SIDEHILL)	
	18, 20, 22, 25 AND 30'	25 - 42		(645301-655300)	20 - 32
I23	CONTOUR MASTER AUGER DRIVE		G13	CUTTERBAR DRIVE, L.H. (SIDEHILL/CONTOUR	
	18, 20, 22, 25 AND 30'	25 - 44		MASTER (655301-)	20 - 34
G13	CONTOUR MASTER CUTTERBAR DRIVE, L.H.		F20	CUTTERBAR KNIFE GUARDS (NON-CLOG)	20 - 17
	(655301-)	20 - 34	J4	CYLINDER, HYDRAULIC, REEL LIFT, MASTER	
E22	CONTOUR MASTER HARNESS			(L.H. END)	30 - 3
	RIGID (660551-)	15 - 70	J3	CYLINDER, HYDRAULIC, REEL LIFT, SLAVE	
F23	CONTOUR MASTER KNIFE DRIVE CASE	20 - 20		R.H. END	30 - 2
C11	CONTOUR MASTER SAFETY CABLE		J20	CYLINDER, REEL FORE/AFT (LH)	
	(660301-)	15 - 8		(OPTIONAL)	30 - 19
E15	CONTOUR MASTER SENSOR AND MOUNTING (L.H)		J19	CYLINDER, REEL FORE/AFT (RH)	
	FLEX (660302-)	15 - 62		(OPTIONAL)	30 - 18
E13	CONTOUR MASTER SENSOR AND MOUNTING (R.H)				
	FLEX (660302-)	15 - 60			
E17	CONTOUR MASTER SENSOR HARNESS				
	FLEX	15 - 64			
E18	CONTOUR MASTER SENSOR HARNESS				
	FLEX (655301-)	15 - 66			
G1	CONTOURMASTER KNIFE DRIVE CASE	20 - 22	I11	DECAL, DRIVE SHAFT (SIDEHILL)	
E7	CONTROL, DIAL-A-MATIC HEADER HEIGHT			(-640500) 6600/6620 COMBINES	25 - 32
	FLEX (-655300)	15 - 54	G9	DECAL, DRIVE SHAFT (SIDEHILL)	
E9	CONTROL, DIAL-A-MATIC HEADER HEIGHT			(-645300) (9500SH COMBINES)	20 - 30
	FLEX (-655300)	15 - 56	I13	DECAL, DRIVE SHAFT (SIDEHILL/CONTOUR	
E8	CONTROL, DIAL-A-MATIC HEADER HEIGHT			MASTER (645301-655300) 9500SH COMBINES	25 - 34
	FLEX (655301-)	15 - 55	I15	DECAL, DRIVE SHAFT (SIDEHILL/CONTOUR	
E11	CONTROL, DIAL-A-MATIC HEADER HEIGHT			MASTER)(655301-665300)(9500SH COMBINE)	25 - 36
	FLEX (655301-)	15 - 58	I17	DECAL, DRIVE SHAFT (SIDEHILL/CONTOUR	
E17	CONTROL, DIAL-A-SPEED			MASTER)(655301-665300)(9500SH COMBINE)	25 - 38
	FLEX	15 - 64	I21	DECAL, DRIVE SHAFT (SIDEHILL/CONTOUR	
E18	CONTROL, DIAL-A-SPEED			MASTER)(665301-)18,20,22,25,30'	25 - 42
	FLEX (655301-)	15 - 66	I23	DECAL, DRIVE SHAFT (SIDEHILL/CONTOUR	
K6	CONVERSION HOSES AND COUPLERS			MASTER)(665301-)18,20,22,25,30'	25 - 44
	PLATFORMS (625001-)	30 - 30	I19	DECAL, DRIVE SHAFT (SIDEHILL/CONTOUR	
K6	CONVERSION HOSES AND COUPLERS			MASTER)(665401-) 15 FT (9500SH)	25 - 40
	20 SERIES COMBINES (600001-622500)	30 - 30	K16	DECALS, R.H. AND L.H.	40 - 4
K6	COUPLER AND HOSE CONVERSION		K18	DECALS, REAR	40 - 6
	PLATFORMS (625001-)	30 - 30	K20	DECALS, RIGHT-HAND - ITALY ONLY	
				(660617-)	40 - 8

D

ALPHABETICAL INDEX - CONTINUED

GRID		PAGE	GRID		PAGE
E17	DIAL-A-MATIC HEADER HEIGHT CONTROL FLEX	15 - 64	B18	DRIVE SHAFT, SLAT REEL 920, 922, 924, 925, 930 (-655300)	10 - 28
E7	DIAL-A-MATIC HEADER HEIGHT CONTROL FLEX (-655300).....	15 - 54	B20	DRIVE SHAFT, SLAT REEL 920, 922, 925, 930 (655301-)	10 - 30
E9	DIAL-A-MATIC HEADER HEIGHT CONTROL FLEX (-655300).....	15 - 56	B15	DRIVE SHAFT, SLAT REEL-913, 915, 918,920 922, 924, 925 AND 930 (645301-655300)	10 - 24
E11	DIAL-A-MATIC HEADER HEIGHT CONTROL FLEX (655301-).....	15 - 58	K14	DRIVE SHEAVES, L.H. SIDE	40 - 1
E18	DIAL-A-MATIC HEADER HEIGHT CONTROL FLEX (655301-).....	15 - 66	K14	DRIVE TIGHTENERS, L.H. SIDE	40 - 1
E8	DIAL-A-MATIC HEADER HEIGHT CONTROL FLEX (655301-)	15 - 55	K15	DRIVE TIGHTENERS, R.H. SIDE.....	40 - 2
E17	DIAL-A-SPEED CONTROL FLEX	15 - 64	I3	DRIVE, AUGER (-635100).....	25 - 24
E18	DIAL-A-SPEED CONTROL FLEX (655301-).....	15 - 66	I5	DRIVE, AUGER (635101-655300)	25 - 26
E20	DIAL-A-SPEED WIRING HARNESS RIGID (-655300)	15 - 68	I7	DRIVE, AUGER (655301-665300)	25 - 28
E21	DIAL-A-SPEED WIRING HARNESS RIGID (655301-)	15 - 69	I9	DRIVE, AUGER (665301-).....	25 - 30
E22	DIAL-A-SPEED WIRING HARNESS RIGID (660551-)	15 - 70	G3	DRIVE, CUTTERBAR (-655300).....	20 - 24
D21	DIVIDER POINT SHOE (FLEX).....	15 - 44	G5	DRIVE, CUTTERBAR (655301-)	20 - 26
D13	DIVIDER POINTS RIGID (-655300)	15 - 36	G9	DRIVE, CUTTERBAR (SIDEHILL) (-645300) (9500SH COMBINES)	20 - 30
D15	DIVIDER POINTS RIGID (655301-).....	15 - 38	G7	DRIVE, CUTTERBAR - EUROPEAN	20 - 28
D21	DIVIDER POINTS - FRONT (FLEX) (665301-).....	15 - 44	G11	DRIVE, CUTTERBAR, L.H. (SIDEHILL) (645301-655300)	20 - 32
D23	DIVIDER POINTS - REAR (FLEX) (TWO-PIECE) (665301-).....	15 - 46	G13	DRIVE, CUTTERBAR, L.H.(SIDEHILL/CONTOUR MASTER (655301-).....	20 - 34
D17	DIVIDER, LONG FLEX (-655300).....	15 - 40	G21	DRIVE, CUTTERBAR, SUPPORT SPRING FLEX (-655300).....	20 - 43
D19	DIVIDER, LONG FLEX (655301-).....	15 - 42	G22	DRIVE, CUTTERBAR, SUPPORT SPRING FLEX (655301-)	20 - 44
K14	DRIVE BELT, L.H. SIDE	40 - 1	B7	DRIVE, PICKUP REEL, R.H. MOUNTING AND GEARS (645301-655300)	10 - 16
G1	DRIVE CASE, KNIFE.....	20 - 22	B9	DRIVE, PICKUP REEL, R.H. MOUNTING AND GEARS (655301-)	10 - 18
F21	DRIVE CASE, KNIFE (-655300).....	20 - 18	E		
F23	DRIVE CASE, KNIFE (655301-).....	20 - 20	B5	ECCENTRIC SPIDER, PICKUP REEL (645301-)	10 - 14
K15	DRIVE CHAINS AND SPROCKETS, R.H. SIDE	40 - 2	K11	END SHIELD (655301-).....	35 - 4
G9	DRIVE SHAFT DECAL (SIDEHILL) (-645300) (9500SH COMBINES)	20 - 30	K9	END SHIELD AND MOUNTING (-635100).....	35 - 2
I11	DRIVE SHAFT, DECAL (SIDEHILL) (-640500) 6600/6620 COMBINES	25 - 32	K10	END SHIELD AND MOUNTING (635101-655300)	35 - 3
I13	DRIVE SHAFT, DECAL (SIDEHILL/CONTOUR MASTER (645301-655300) 9500SH COMBINES.....	25 - 34	K12	END SHIELD AND MOUNTING (655301-).....	35 - 5
I15	DRIVE SHAFT, DECAL (SIDEHILL/CONTOUR MASTER)(655301-665300)(9500SH COMBINE)	25 - 36	H5	EXTENSIONS, FLIGHT, AUGER (-655300).....	25 - 1
I17	DRIVE SHAFT, DECAL (SIDEHILL/CONTOUR MASTER)(655301-665300)(9500SH COMBINE)	25 - 38	H6	EXTENSIONS, FLIGHT, AUGER (655301-)	25 - 2
I21	DRIVE SHAFT, DECAL (SIDEHILL/CONTOUR MASTER)(665301-)18,20,22,25,30'	25 - 42	F		
I23	DRIVE SHAFT, DECAL (SIDEHILL/CONTOUR MASTER)(665301-)18,20,22,25,30'	25 - 44	C20	FEED PLATES, MAIN SILL RIGID (-655300)	15 - 18
I19	DRIVE SHAFT, DECAL (SIDEHILL/CONTOUR MASTER)(665401-) 15 FT. (9500SH)	25 - 40	C22	FEED PLATES, MAIN SILL RIGID (655301-)	15 - 20
G15	DRIVE SHAFT, HEADER (SIDEHILL) (-640500).....	20 - 36	A17	FINGER, PICKUP REEL (-645300).....	10 - 2
G16	DRIVE SHAFT, HEADER - SIDEHILL (645301-).....	20 - 38	H17	FINGERS, AUGER (-655300)	25 - 14
B16	DRIVE SHAFT, SLAT REEL (655301-).....	10 - 25			
B17	DRIVE SHAFT, SLAT REEL 913, 915, 918.....	10 - 26			

ALPHABETICAL INDEX - CONTINUED

GRID	PAGE	GRID	PAGE
H19	25 - 16	E17	15 - 64
H7	25 - 4	E18	15 - 66
H9	25 - 6	E20	15 - 68
C18	15 - 16	E21	15 - 69
D11	15 - 34	E22	15 - 70
H5	25 - 1	E17	15 - 64
H6	25 - 2	E18	15 - 66
C12	15 - 10	E17	15 - 64
C14	15 - 12	E18	15 - 66
C16	15 - 14	E20	15 - 68
K3	30 - 26	E21	15 - 69
J21	30 - 20	E22	15 - 70
J23	30 - 22	E17	15 - 64
K1	30 - 24	E18	15 - 66
J20	30 - 19	E20	15 - 68
J19	30 - 18	E21	15 - 69
C7	15 - 4	E22	15 - 70
C9	15 - 6	E24	15 - 72
C5	15 - 2	G15	20 - 36
D23	15 - 46	G16	20 - 38
D21	15 - 44	E17	15 - 64
G			
B16	10 - 25	E18	15 - 66
B7	10 - 16	E7	15 - 54
A20	10 - 5	E9	15 - 56
B16	10 - 25	E8	15 - 55
B15	10 - 24	E11	15 - 58
A20	10 - 5	E9	15 - 56
F18	20 - 15	E11	15 - 58
F19	20 - 16	K6	30 - 30
F20	20 - 17	K6	30 - 30
F4	20 - 1	J13	30 - 12
H			
E22	15 - 70	J14	30 - 13
		J9	30 - 8
		J11	30 - 10
		H11	25 - 8
		H13	25 - 10
		H15	25 - 12
		J4	30 - 3
		J3	30 - 2

ALPHABETICAL INDEX - CONTINUED

<i>GRID</i>		<i>PAGE</i>	<i>GRID</i>		<i>PAGE</i>
J13	HYDRAULIC DRIVE REEL HOSES (645301-655300)	30 - 12	J5	LINES, HYDRAULIC REEL DRIVE (-655300)	30 - 4
J14	HYDRAULIC DRIVE REEL HOSES (655301-)	30 - 13	J7	LINES, HYDRAULIC REEL DRIVE (655301-)	30 - 6
J21	HYDRAULIC LINE, REEL FORE AND AFT (OPTIONAL) (-655300)	30 - 20	D17	LONG DIVIDER FLEX (-655300)	15 - 40
J23	HYDRAULIC LINES, REEL FORE AND AFT (655301-)	30 - 22	D19	LONG DIVIDER FLEX (655301-)	15 - 42
K1	HYDRAULIC LINES, REEL FORE AND AFT (655301-)	30 - 24			
	I			M	
G18	IDLER, KNIFE DRIVE (-655300)	20 - 40	C20	MAIN SILL, FEED PLATES, AND SUPPORTS RIGID (-655300)	15 - 18
G20	IDLER, KNIFE DRIVE (655301-)	20 - 42	C22	MAIN SILL, FEED PLATES, AND SUPPORTS RIGID (655301-)	15 - 20
E9	INDICATOR, HEIGHT SENSING RANGE FLEX (-655300)	15 - 56	E25	MARKER LIGHTS	15 - 73
E11	INDICATOR, HEIGHT SENSING RANGE FLEX (655301-)	15 - 58	E17	MARKER LIGHTS HARNESS FLEX	15 - 64
	K		E18	MARKER LIGHTS HARNESS FLEX (655301-)	15 - 66
I25	KEY STOCK, METRIC KIT	25 - 46	E20	MARKER LIGHTS HARNESS RIGID (-655300)	15 - 68
C18	KIT, FLEX PLATFORM TILT ADAPTER	15 - 16	E21	MARKER LIGHTS HARNESS RIGID (655301-)	15 - 69
I25	KIT, METRIC KEY STOCK	25 - 46	E22	MARKER LIGHTS HARNESS RIGID (660551-)	15 - 70
D11	KIT, PLASTIC SKID SHOE, FLEX	15 - 34	I25	METRIC KEY STOCK KIT	25 - 46
F5	KNIFE AND MOUNTINGS, BOLTED (-655300)	20 - 2	J17	MOTOR, REEL (EATON) (655583-)	30 - 16
F9	KNIFE AND MOUNTINGS, BOLTED (655301-)	20 - 6	J15	MOTOR, REEL (ROSS NO. K85921) (-655582)	30 - 14
G1	KNIFE DRIVE CASE	20 - 22	E7	MOUNTING FLEX (-655300)	15 - 54
F21	KNIFE DRIVE CASE (-655300)	20 - 18	E8	MOUNTING FLEX (655301-)	15 - 55
F23	KNIFE DRIVE CASE (655301-)	20 - 20	B7	MOUNTING AND GEARS, PICKUP REEL DRIVE R.H. (645301-655300)	10 - 16
G18	KNIFE DRIVE IDLER AND TIGHTENER (-655300)	20 - 40	B9	MOUNTING AND GEARS, PICKUP REEL DRIVE, R.H. (655301-)	10 - 18
G20	KNIFE DRIVE IDLER AND TIGHTENER (655301-)	20 - 42	F7	MOUNTING, BOLTED KNIFE (-655300)	20 - 4
F20	KNIFE GUARDS, CUTTERBAR (NON-CLOG)	20 - 17	F11	MOUNTING, BOLTED KNIFE (655301-)	20 - 8
F17	KNIFE STORAGE BRACKET AND SHIELD	20 - 14	F15	MOUNTING, BOLTED KNIFE - DURA-CUT	20 - 12
F7	KNIFE, BOLTED (-655300)	20 - 4	F13	MOUNTING, BOLTED KNIFE - DURA-LITE	20 - 10
F11	KNIFE, BOLTED (655301-)	20 - 8	G21	MOUNTING, CUTTERBAR DRIVE FLEX (-655300)	20 - 43
F15	KNIFE, BOLTED - DURA-CUT	20 - 12	G22	MOUNTING, CUTTERBAR DRIVE FLEX (655301-)	20 - 44
F13	KNIFE, BOLTED - DURA-LITE	20 - 10	K9	MOUNTING, END SHIELD (-635100)	35 - 2
F17	KNIFE, SPARE	20 - 14	K11	MOUNTING, END SHIELD (655301-)	35 - 4
	L		K12	MOUNTING, END SHIELD (655301-)	35 - 5
B17	L.H. MOUNTING, SLAT REEL 913, 915, 918	10 - 26	B11	MOUNTING, PICKUP REEL SHAFTS, L.H. (645301-655300)	10 - 20
K20	LEFT-HAND DECALS - ITALY ONLY (660617-)	40 - 8	B13	MOUNTING, PICKUP REEL SHAFTS, L.H. (655301-)	10 - 22
F4	LIFTING GUARDS	20 - 1	E15	MOUNTING, SENSOR - CONTOUR MASTER (L.H.) FLEX (660302-)	15 - 62
E17	LIGHT, MARKER HARNESS FLEX	15 - 64	E13	MOUNTING, SENSOR - CONTOUR MASTER (R.H.) FLEX (660302-)	15 - 60
E18	LIGHT, MARKER HARNESS FLEX (655301-)	15 - 66	B18	MOUNTING, SLAT REEL, L.H. 920, 922, 924, 925, 930 (-655300)	10 - 28
E25	LIGHTS, MARKER	15 - 73			
E24	LIGHTS, STUBBLE, HARNESS	15 - 72			

ALPHABETICAL INDEX - CONTINUED

<i>GRID</i>		<i>PAGE</i>	<i>GRID</i>		<i>PAGE</i>
B20	MOUNTING, SLAT REEL, L.H. 920, 922, 925, 930 (655301-)	10 - 30	A17	PICKUP REEL SPIDER PLATE (-645300)	10 - 2
B16	MOUNTING, SLAT REEL, R.H. (655301-)	10 - 25	B22	PIN, REEL ARM (-655300)	10 - 32
B15	MOUNTING, SLAT REEL, R.H.-913, 915, 918, 920, 922, 924, 925,930 (645301-655300)	10 - 24	B24	PIN, REEL ARM (655301-)	10 - 35
A21	MOUNTINGS, PICKUP REEL, L.H. (-645300)	10 - 6	D11	PLASTIC SKID SHOE, FLEX	15 - 34
A20	MOUNTINGS, PICKUP REEL, R.H. (-645300)	10 - 5	A17	PLATE, PICKUP REEL SPIDER (-645300)	10 - 2
K10	MOUNTIONG, END SHIELD (635101-655300)	35 - 3	C20	PLATES, MAIN SILL FEED RIGID (-655300)	15 - 18
O					
J9	OIL LINES, REEL LIFT (-655300)	30 - 8	C22	PLATES, MAIN SILL FEED RIGID (655301-)	15 - 20
J11	OIL LINES, REEL LIFT (655301-)	30 - 10	D5	PLATES, PROTECTION RIGID (-655300)	15 - 28
D21	OUTRIGGER, DIVIDER POINT (FLEX) (665301-) (TWO-PIECE)	15 - 44	D6	PLATES, PROTECTION RIGID (655301-)	15 - 29
P					
J13	PICKUP AND SLAT REEL, HYDRAULIC DRIVE HOSES (645301-655300)	30 - 12	D5	PLATES, SKID RIGID (-655300)	15 - 28
J14	PICKUP AND SLAT REEL, HYDRAULIC DRIVE HOSES (655301-)	30 - 13	D6	PLATES, SKID RIGID (655301-)	15 - 29
A17	PICKUP REEL (-645300)	10 - 2	F18	PLATES, WEAR (-645300)	20 - 15
A23	PICKUP REEL (645301-655300)	10 - 8	F19	PLATES, WEAR (655301-)	20 - 16
B1	PICKUP REEL (655301-)	10 - 10	C18	PLATFORM, FLEX TILT ADAPTER KIT	15 - 16
B3	PICKUP REEL (655301-)	10 - 12	D13	POINTS, DIVIDER RIGID (-655300)	15 - 36
A17	PICKUP REEL ARM (-645300)	10 - 2	D15	POINTS, DIVIDER RIGID (655301-)	15 - 38
A21	PICKUP REEL DRIVE SHAFT (-645300)	10 - 6	D5	PROTECTION PLATES RIGID (-655300)	15 - 28
B7	PICKUP REEL DRIVE, R.H. MOUNTING AND GEARS (645301-655300)	10 - 16	D6	PROTECTION PLATES RIGID (655301-)	15 - 29
B9	PICKUP REEL DRIVE, R.H. MOUNTING AND GEARS (655301-)	10 - 18	E5	PUSH LINK (FLEX)	15 - 52
A19	PICKUP REEL ECCENTRIC SPIDER (-645300)	10 - 4	R		
B5	PICKUP REEL ECCENTRIC SPIDER (645301-)	10 - 14	D23	REAR DIVIDER POINTS (FLEX) (TWO-PIECE) (665301-)	15 - 46
A17	PICKUP REEL FINGER (-645300)	10 - 2	B22	REEL ARM (-655300)	10 - 32
A20	PICKUP REEL GEARS (-645300)	10 - 5	B24	REEL ARM (655301-)	10 - 35
A20	PICKUP REEL GUARD (-645300)	10 - 5	J13	REEL DRIVE HOSES, PICKUP (645301-655300)	30 - 12
A21	PICKUP REEL MOUNTINGS, L.H. (-645300)	10 - 6	J14	REEL DRIVE HOSES, PICKUP REEL (655301-)	30 - 13
A20	PICKUP REEL MOUNTINGS, R.H. (-645300)	10 - 5	J5	REEL DRIVE LINES (-655300)	30 - 4
B11	PICKUP REEL SHAFTS AND L.H. MOUNTING (645301-655300)	10 - 20	J7	REEL DRIVE LINES (655301-)	30 - 6
B13	PICKUP REEL SHAFTS AND L.H. MOUNTING (655301-)	10 - 22	K4	REEL FORE AND AFT (SLAT REEL) HARDWARE (-655300)	30 - 27
A17	PICKUP REEL SLAT (-645300)	10 - 2	K5	REEL FORE AND AFT (SLAT REEL) HARDWARE (655301-)	30 - 28
			K3	REEL FORE AND AFT HARDWARE (PICKUP REEL) ..	30 - 26
			J21	REEL FORE AND AFT HYDRAULIC LINES (OPTIONAL) (-655300)	30 - 20
			J23	REEL FORE AND AFT HYDRAULIC LINES (655301-)	30 - 22
			K1	REEL FORE AND AFT HYDRAULIC LINES (655301-)	30 - 24
			J20	REEL FORE/AFT CYLINDER (LH) (OPTIONAL)	30 - 19

ALPHABETICAL INDEX - CONTINUED

<i>GRID</i>	<i>PAGE</i>	<i>GRID</i>	<i>PAGE</i>
J19 REEL FORE/AFT CYLINDER (RH) (OPTIONAL).....	30 - 18	I1 SHAFT, AUGER DRIVE (-635100).....	25 - 22
J4 REEL LIFT MASTER CYLINDER (L.H. END)	30 - 3	I3 SHAFT, AUGER DRIVE (-635100).....	25 - 24
J9 REEL LIFT OIL LINES (-655300).....	30 - 8	I5 SHAFT, AUGER DRIVE (635101-655300)	25 - 26
J11 REEL LIFT OIL LINES (655301-).....	30 - 10	I7 SHAFT, AUGER DRIVE (655301-665300)	25 - 28
J3 REEL LIFT SLAVE CYLINDER R.H. END	30 - 2	I9 SHAFT, AUGER DRIVE (665301-).....	25 - 30
J17 REEL MOTOR (EATON) (655583-).....	30 - 16	I11 SHAFT, AUGER DRIVE (SIDEHILL) (-640500) 6600/6620 COMBINES	25 - 32
J15 REEL MOTOR (ROSS NO. K85921) (-655582)	30 - 14	I13 SHAFT, AUGER DRIVE (SIDEHILL/CONTOUR MASTER (645301-655300) 9500SH COMBINES.....	25 - 34
B17 REEL SLAT 913, 915, 918.....	10 - 26	I15 SHAFT, AUGER DRIVE (SIDEHILL/CONTOUR MASTER)(655301-665300)(9500SH COMBINE)	25 - 36
A17 REEL, PICKUP (-645300)	10 - 2	I17 SHAFT, AUGER DRIVE (SIDEHILL/CONTOUR MASTER)(655301-665300)(9500SH COMBINE)	25 - 38
A23 REEL, PICKUP (645301-655300)	10 - 8	I21 SHAFT, AUGER DRIVE (SIDEHILL/CONTOUR MASTER)(665301-)18,20,22,25,30'	25 - 42
B1 REEL, PICKUP (655301-).....	10 - 10	I23 SHAFT, AUGER DRIVE (SIDEHILL/CONTOUR MASTER)(665301-)18,20,22,25,30'	25 - 44
B3 REEL, PICKUP (655301-).....	10 - 12	I19 SHAFT, AUGER DRIVE (SIDEHILL/CONTOUR MASTER)(665401-) 15 FT (9500SH)	25 - 40
B7 REEL, PICKUP DRIVE, R.H. MOUNTING AND GEARS (645301-655300)	10 - 16	G3 SHAFT, CUTTERBAR DRIVE (-655300)	20 - 24
B9 REEL, PICKUP DRIVE, R.H. MOUNTING AND GEARS (655301-).....	10 - 18	G5 SHAFT, CUTTERBAR DRIVE (655301-).....	20 - 26
B11 REEL, PICKUP SHAFTS AND L.H. MOUNTING (645301-655300)	10 - 20	G7 SHAFT, CUTTERBAR DRIVE - EUROPEAN	20 - 28
B13 REEL, PICKUP SHAFTS AND L.H. MOUNTING (655301-).....	10 - 22	G15 SHAFT, HEADER DRIVE (SIDEHILL) (-640500)	20 - 36
B5 REEL, PICKUP, ECCENTRIC SPIDER (645301-).....	10 - 14	G16 SHAFT, HEADER DRIVE - SIDEHILL (645301-).....	20 - 38
E5 REINFORCEMENT (FLEX)	15 - 52	A21 SHAFT, PICKUP REEL (-645300)	10 - 6
K20 RIGHT-HAND DECALS - ITALY ONLY (660617-).....	40 - 8	H17 SHAFTS, AUGER (-655300)	25 - 14
S			
C11 SAFETY CABLE (SIDEHILL/CONTOUR MASTER) (660301-).....	15 - 8	H19 SHAFTS, AUGER (655301-).....	25 - 16
C24 SEALS, STAINLESS STEEL FLEX (-655300).....	15 - 22	H7 SHAFTS, FINGERS, CROSS AUGER, BEARINGS (-635100)	25 - 4
D1 SEALS, STAINLESS STEEL FLEX (655301-).....	15 - 24	H9 SHAFTS, FINGERS, CROSS AUGER, BEARINGS (-635100)	25 - 6
D3 SEALS, STAINLESS STEEL FLEX (655301-).....	15 - 26	B11 SHAFTS, PICKUP REEL AND L.H. MOUNTING (645301-655300)	10 - 20
E7 SENSING BOX FLEX (-655300).....	15 - 54	B13 SHAFTS, PICKUP REEL AND L.H. MOUNTING (655301-).....	10 - 22
E8 SENSING BOX FLEX (655301-)	15 - 55	G9 SHEAVE, CUTTERBAR DRIVE (SIDEHILL) (-645300) (9500SH COMBINES)	20 - 30
E17 SENSOR HARNESS, CONTOUR MASTER FLEX	15 - 64	G18 SHEAVE, IDLER, KNIFE DRIVE (-655300)	20 - 40
E18 SENSOR HARNESS, CONTOUR MASTER FLEX (655301-).....	15 - 66	G20 SHEAVE, IDLER, KNIFE DRIVE (655301-).....	20 - 42
E13 SENSOR, CONTOUR MASTER (R.H.) FLEX (660302-).....	15 - 60	I1 SHIELD, AUGER DRIVE (-635100)	25 - 22
E15 SENSOR, MOUNTUNG, CONTOUR MASTER (L.H.) FLEX (660302-).....	15 - 62	I3 SHIELD, AUGER DRIVE (-635100)	25 - 24
H11 SHAFT AND AUGER (635101-655300)	25 - 8	I5 SHIELD, AUGER DRIVE (635101-655300)	25 - 26
H13 SHAFT AND AUGER (655301-13MAY96)	25 - 10	I7 SHIELD, AUGER DRIVE (655301-665300)	25 - 28
H15 SHAFT AND CROSS AUGER (655301-).....	25 - 12	I9 SHIELD, AUGER DRIVE (665301-).....	25 - 30
		I11 SHIELD, AUGER DRIVE (SIDEHILL) (-640500) 6600/6620 COMBINES	25 - 32
		I13 SHIELD, AUGER DRIVE (SIDEHILL/CONTOUR MASTER (645301-655300) 9500SH COMBINES.....	25 - 34

ALPHABETICAL INDEX - CONTINUED

<i>GRID</i>		<i>PAGE</i>	<i>GRID</i>		<i>PAGE</i>
I15	SHIELD, AUGER DRIVE (SIDEHILL/CONTOUR MASTER)(655301-665300)(9500SH COMBINE)	25 - 36	C22	SILL, MAIN RIGID (655301-)	15 - 20
I17	SHIELD, AUGER DRIVE (SIDEHILL/CONTOUR MASTER)(655301-665300)(9500SH COMBINE)	25 - 38	D5	SKID PLATES RIGID (-655300)	15 - 28
I21	SHIELD, AUGER DRIVE (SIDEHILL/CONTOUR MASTER)(665301-)18,20,22,25,30'	25 - 42	D6	SKID PLATES RIGID (655301-)	15 - 29
I23	SHIELD, AUGER DRIVE (SIDEHILL/CONTOUR MASTER)(665301-)18,20,22,25,30'	25 - 44	D7	SKID SHOES FLEX (-655300).....	15 - 30
I19	SHIELD, AUGER DRIVE (SIDEHILL/CONTOUR MASTER)(665401-) 15 FT.(9500SH)	25 - 40	D9	SKID SHOES FLEX (655301-).....	15 - 32
G3	SHIELD, CUTTERBAR DRIVE (-655300)	20 - 24	B17	SLAT REEL 913, 915, 918.....	10 - 26
G5	SHIELD, CUTTERBAR DRIVE (655301-)	20 - 26	B17	SLAT REEL ARM 913, 915, 918.....	10 - 26
G9	SHIELD, CUTTERBAR DRIVE (SIDEHILL) (-645300) (9500SH COMBINES)	20 - 30	B18	SLAT REEL ARM 920, 922, 924, 925, 930 (-655300)	10 - 28
G7	SHIELD, CUTTERBAR DRIVE - EUROPEAN	20 - 28	B20	SLAT REEL ARM 920, 922, 925, 930 (655301-)	10 - 30
K9	SHIELD, END (-635100)	35 - 2	B16	SLAT REEL DRIVE SHAFT (655301-)	10 - 25
K10	SHIELD, END (635101-655300)	35 - 3	B17	SLAT REEL DRIVE SHAFT 913, 915, 918.....	10 - 26
K12	SHIELD, END (655301-)	35 - 5	B18	SLAT REEL DRIVE SHAFT 920, 922, 924, 925, 930 (-655300)	10 - 28
F17	SHIELD, KNIFE STORAGE	20 - 14	B20	SLAT REEL DRIVE SHAFT 920, 922, 925, 930 (655301-)	10 - 30
A21	SHIELD, PICK UP REEL (-645300)	10 - 6	B15	SLAT REEL DRIVE SHAFT-913, 915, 918, 920 922, 924, 925 AND 930 (645301-655300)	10 - 24
B16	SHIELD, SLAT REEL (655301-)	10 - 25	B16	SLAT REEL GEARS (655301-)	10 - 25
B15	SHIELD, SLAT REEL-913, 915, 918, 920, 922, 924, 925 AND 930 (645301-655300)	10 - 24	B15	SLAT REEL GEARS-913, 915, 918, 920, 922, 924, 925 AND 930 (645301-655300)	10 - 24
H21	SHIELDS, AUGER (-655300)	25 - 18	B17	SLAT REEL MOUNTING, L.H. 913, 915, 918.....	10 - 26
H23	SHIELDS, AUGER (655301-)	25 - 20	B18	SLAT REEL MOUNTING, L.H. 920, 922, 924, 925, 930 (-655300)	10 - 28
K9	SHIELDS, DRIVE (-635100)	35 - 2	B20	SLAT REEL MOUNTING, L.H. 920, 922, 925, 930 (655301-)	10 - 30
K10	SHIELDS, DRIVE (635101-655300)	35 - 3	B16	SLAT REEL MOUNTING, R.H. (655301-)	10 - 25
K12	SHIELDS, DRIVE (655301-)	35 - 5	B15	SLAT REEL MOUNTING, R.H.-913, 915, 918, 920, 922, 924, 925,930 (645301-655300)	10 - 24
D21	SHOE, DIVIDER POINT(FLEX)	15 - 44	B16	SLAT REEL SHIELD (655301-)	10 - 25
D7	SHOES, SKID FLEX (-655300).....	15 - 30	B15	SLAT REEL SHIELD-913,915, 918, 920, 922, 924, 925, AND 930 (645301-655300).....	10 - 24
D9	SHOES, SKID FLEX (655301-).....	15 - 32	A17	SLAT, PICKUP REEL (-645300)	10 - 2
G15	SIDEHILL - HEADER DRIVE SHAFT (-640500)	20 - 36	J3	SLAVE CYLINDER R.H. END	30 - 2
I21	SIDEHILL AUGER DRIVE-18,20,22,25 AND 30' (665301-) (9500SH COMBINE)	25 - 42	F17	SPARE KNIFE	20 - 14
I23	SIDEHILL AUGER DRIVE-18,20,22,25 AND 30' (665301-) (9500SH COMBINE)	25 - 44	A19	SPIDER, ECCENTRIC, PICKUP REEL (-645300)	10 - 4
G9	SIDEHILL CUTTERBAR DRIVE (-645300) (9500SH COMBINES)	20 - 30	G21	SPRING, CUTTERBAR DRIVE FLEX (-655300).....	20 - 43
G11	SIDEHILL CUTTERBAR DRIVE, L.H. (645301-655300)	20 - 32	G22	SPRING, CUTTERBAR DRIVE FLEX (655301-)	20 - 44
G13	SIDEHILL CUTTERBAR DRIVE, L.H. (655301-)	20 - 34	D23	SPRING, EXTENSION - TWO-PIECE DIVIDER POINTS (FLEX) (665301-)	15 - 46
C11	SIDEHILL SAFETY CABLE (660301-)	15 - 8	G23	SPRING, STABILIZER FLEX (-655300).....	20 - 45
I15	SIDEHILL/CONTOUR MASTER AUGER DRIVE (655301-665300) (9500SH COMBINE).....	25 - 36	G24	SPRING, STABILIZER FLEX (S.N. 655301-).....	20 - 46
I17	SIDEHILL/CONTOUR MASTER AUGER DRIVE (655301-665300) (9500SH COMBINE).....	25 - 38	H21	SPROCKET, AUGER (-655300)	25 - 18
I19	SIDEHILL/CONTOUR MASTER AUGER DRIVE 15 FT (665401-) (9500SH COMBINE)	25 - 40	H23	SPROCKET, AUGER (655301-)	25 - 20
C20	SILL, MAIN RIGID (-655300)	15 - 18			

ALPHABETICAL INDEX - CONTINUED

<i>GRID</i>		<i>PAGE</i>	<i>GRID</i>		<i>PAGE</i>
I1	SPROCKET, AUGER DRIVE (-635100)	25 - 22	C20	SUPPORTS, MAIN SILL RIGID (-655300)	15 - 18
I3	SPROCKET, AUGER DRIVE (-635100)	25 - 24	C22	SUPPORTS, MAIN SILL RIGID (655301-)	15 - 20
I5	SPROCKET, AUGER DRIVE (635101-655300)	25 - 26		T	
I7	SPROCKET, AUGER DRIVE (655301-665300)	25 - 28	G18	TIGHTENER, KNIFE DRIVE (-655300)	20 - 40
I9	SPROCKET, AUGER DRIVE (665301-)	25 - 30	G20	TIGHTENER, KNIFE DRIVE (655301-)	20 - 42
I11	SPROCKET, AUGER DRIVE (SIDEHILL) (-640500) 6600/6620 COMBINES	25 - 32	K14	TIGHTENERS AND SHEAVE ON L.H. SIDE	40 - 1
I13	SPROCKET, AUGER DRIVE (SIDEHILL/CONTOUR MASTER (645301-655300) 9500SH COMBINES.....	25 - 34	K15	TIGHTENERS AND SPROCKETS, R.H. SIDE.....	40 - 2
I15	SPROCKET, AUGER DRIVE (SIDEHILL/CONTOUR MASTER)(655301-665300)(9500SH COMBINE)	25 - 36	D21	TWO-PIECE DIVIDER POINT (FLEX) (665301-)	15 - 44
I17	SPROCKET, AUGER DRIVE (SIDEHILL/CONTOUR MASTER)(655301-665300)(9500SH COMBINE)	25 - 38	D23	TWO-PIECE DIVIDER POINTS - REAR (FLEX) (665301-)	15 - 46
I21	SPROCKET, AUGER DRIVE (SIDEHILL/CONTOUR MASTER)(665301-)18,20,22,25,30'	25 - 42		W	
I23	SPROCKET, AUGER DRIVE (SIDEHILL/CONTOUR MASTER)(665301-)18,20,22,25,30'	25 - 44	G15	WALTERSCHIED HEADER DRIVE SHAFT, (-640500) (SIDEHILL)	20 - 36
I19	SPROCKET, AUGER DRIVE (SIDEHILL/CONTOUR MASTER)(665401-) 15FT (9500SH).....	25 - 40	F18	WEAR PLATES (-645300)	20 - 15
G3	SPROCKET, CUTTERBAR DRIVE (-655300)	20 - 24	F19	WEAR PLATES (655301-)	20 - 16
G5	SPROCKET, CUTTERBAR DRIVE (655301-)	20 - 26	E17	WIRING HARNESS, CONTOUR MASTER SENSOR FLEX	15 - 64
G7	SPROCKET, CUTTERBAR DRIVE - EUROPEAN	20 - 28	E18	WIRING HARNESS, CONTOUR MASTER SENSOR FLEX (655301-)	15 - 66
E1	STABILIZER FLEX (-655300)	15 - 48	E17	WIRING HARNESS, DIAL-A-MATIC FLEX	15 - 64
E3	STABILIZER FLEX (655301-)	15 - 50	E18	WIRING HARNESS, DIAL-A-MATIC FLEX (655301-)	15 - 66
G23	STABILIZER SPRING FLEX (-655300)	20 - 45	E20	WIRING HARNESS, DIAL-A-SPEED RIGID (-655300)	15 - 68
G24	STABILIZER SPRING FLEX, (S.N. 655301-)	20 - 46	E21	WIRING HARNESS, DIAL-A-SPEED RIGID (655301-)	15 - 69
C24	STAINLESS STEEL SEALS FLEX (-655300)	15 - 22	E22	WIRING HARNESS, DIAL-A-SPEED RIGID (660551-)	15 - 70
D1	STAINLESS STEEL SEALS FLEX (655301-)	15 - 24			
E5	STOP ARM (FLEX)	15 - 52			
K4	STOP, REEL FORE AND AFT (SLAT REEL) (-655300)	30 - 27			
K5	STOP, REEL FORE AND AFT (SLAT REEL) (655301-)	30 - 28			
C12	STRIPPER, FLOOR (-655300)	15 - 10			
C14	STRIPPER, FLOOR (-655300)	15 - 12			
C16	STRIPPER, FLOOR (655301-)	15 - 14			
E24	STUBBLE LIGHTS	15 - 72			
H21	SUPPORT, AUGER (-655300)	25 - 18			
H23	SUPPORT, AUGER (655301-)	25 - 20			
G23	SUPPORT, SPRING STABILIZER FLEX (-655300)	20 - 45			
G24	SUPPORT, STABILIZER SPRING FLEX (S.N. 655301-)	20 - 46			
C12	SUPPORTS AND STRIPPERS (-655300)	15 - 10			
C14	SUPPORTS AND STRIPPERS (-655300)	15 - 12			
C16	SUPPORTS AND STRIPPERS (655301-)	15 - 14			

MEMORANDA

MEMORANDA

A17

REEL

PICKUP REEL (-645300)
HP5055 -UN-01JAN94

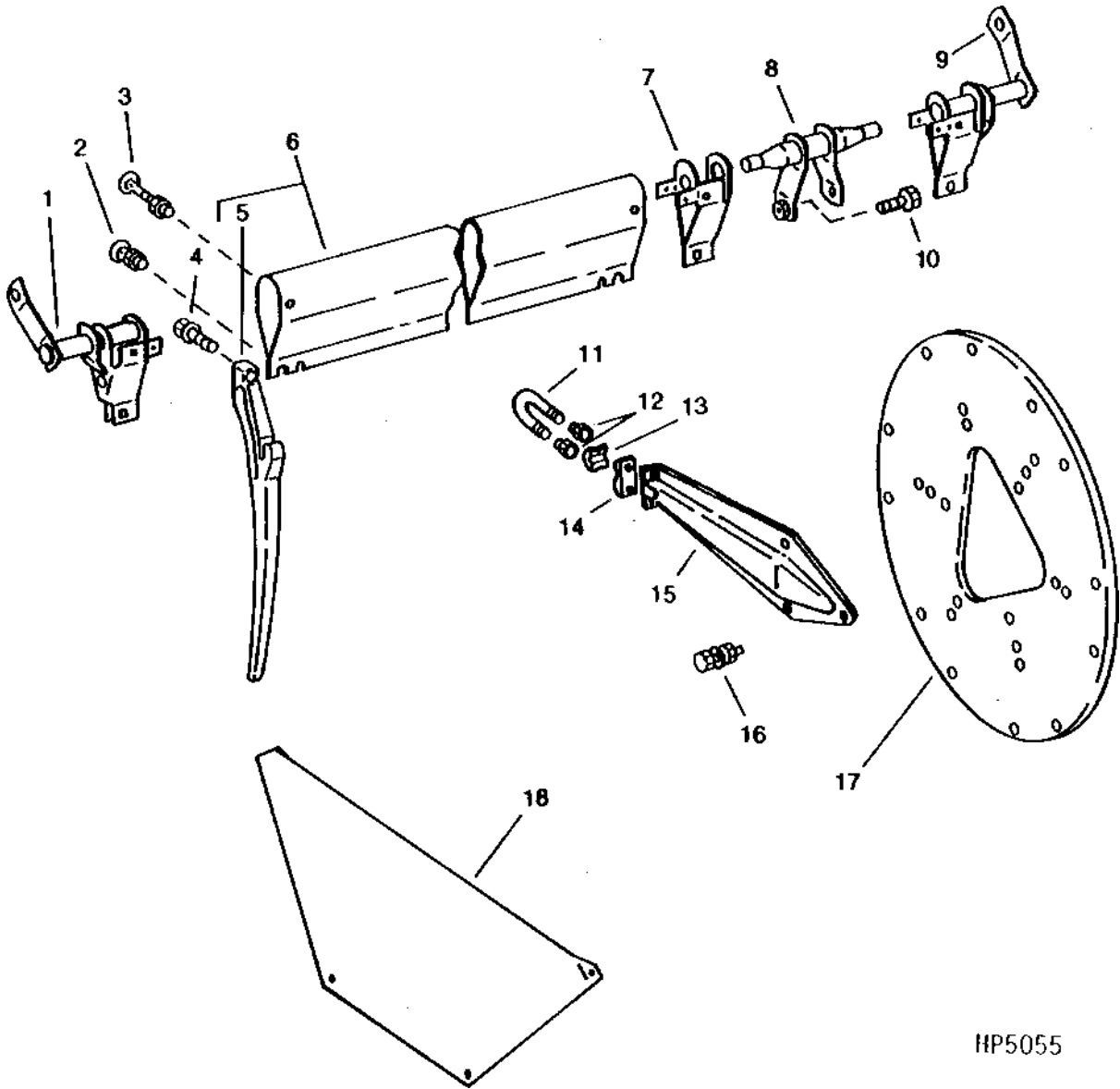

HP5055

A18

REEL

PICKUP REEL (-645300) - CONTINUED

KEY	PART NO.	PART NAME	QTY	SERIAL NO.	REMARKS
1	AH122158	BRACKET	6		R.H.
2	03H1539	BOLT	6		5/16" X 5/8"
	H127039	NUT	6		7.925 MM (5/16") CADMIUM, (SUB H76696)
	H76696	LOCK NUT	6		7.925 MM (5/16")
3	03H1791	BOLT	6		5/16" X 2-1/2"
	H127039	NUT	6		7.925 MM (5/16") CADMIUM, (SUB H76696)
	H76696	LOCK NUT	6		7.925 MM (5/16")
4	H127037	SCREW	AR		4.166 X 19.050 MM (0.164" X 3/4") NO. 8 (ORIGINAL EQUIPMENT) (913-180 USED; 915-228 USED; 918-270 USED; 920-300 USED; 922-324 USED; 924-360 USED; 925-384 USED AND 930-456 USED)
	37H160	SCREW	AR		NO. 10 (SUB FOR H127037 WHEN HOLE IN BAT IS STRIPPED)
	AH129419	SCREW AND WASHER KIT	AR		(SUB FOR 37H160 WHEN NO. 10 HOLE IS STRIPPED)
5	H127035	FINGER	AR		(913-180 USED; 915-228 USED; 918-270 USED; 920-300 USED; 922-324 USED; 924-360 USED; 925-384 USED AND 930-456 USED)
6	AH126400	FINGER	12		(913) R.H AND L.H.
	AH126401	FINGER	12		(915) R.H. AND L.H.
	AH122150	FINGER	6		(918) CENTER
	AH122151	FINGER	AR		(918) RH AND LH -12 USED;(920) CENTER-6 USED)
	AH122152	FINGER	12		(920) R.H. AND L.H.
	AH122153	FINGER	18		(922)
	AH122156	FINGER	18	-635100	(924)
	AH132628	FINGER	12		(925) R.H. AND L.H.
	AH132629	FINGER	12		(925) CENTER
	AH122154	FINGER	12		(930) R.H. AND L.H.
	AH122155	FINGER	12		(930) CENTER
7	AH122160	RETAINER	AR		(913,915,918,920,922,924,925-24 USED; 930-36 USED)
8	AH122159	BRACKET	AR		CENTER (913, 915, 918, 920, 922, 924, 925 - 12 USED; 930 - 18 USED)
9	AH122157	BRACKET	6		L.H.
10	H127043	BOLT	AR		7.925 X 15.748 MM (5/16" X 0.620")
11	E40203	U-BOLT	AR		(913,915,918,920,922,924-36 USED; 925 AND 930-42 USED)
12	E45229	LOCK NUT	AR		6.350 MM (1/4") (913,915,918,920,922,924-72 USED; 925 AND 930-84 USED)
13	E40205	CAP	AR		(913,915,918,920,922,924-36 USED; 925 AND 930-42 USED)
14	E40206	BASE	AR		(913,915,918,920,922,924-36 USED; 925 AND 930-42 USED)
15	AH97207	ARM	AR		(913,915,918,920,922,924-36 USED; 925 AND 930-42 USED)
16	19H2020	CAP SCREW	72		5/16" X 1/2"
	12M7065	LOCK WASHER	72		0.319"
	14H785	NUT	72		7.925 MM (5/16")
17	H98688	PLATE	4		(913, 915, AND 918)
	H98689	PLATE	AR		(920, 922, 924-4 USED; 925 AND 930-5 USED)
18	H134693	SHIELD	1		

BH77217 (COMPLETE GOODS) SPIDER ASSEMBLY - 20,22,24,25,30'

A19

REEL

PICKUP REEL ECCENTRIC SPIDER (-645300)
 HP4952 -UN-01JAN94

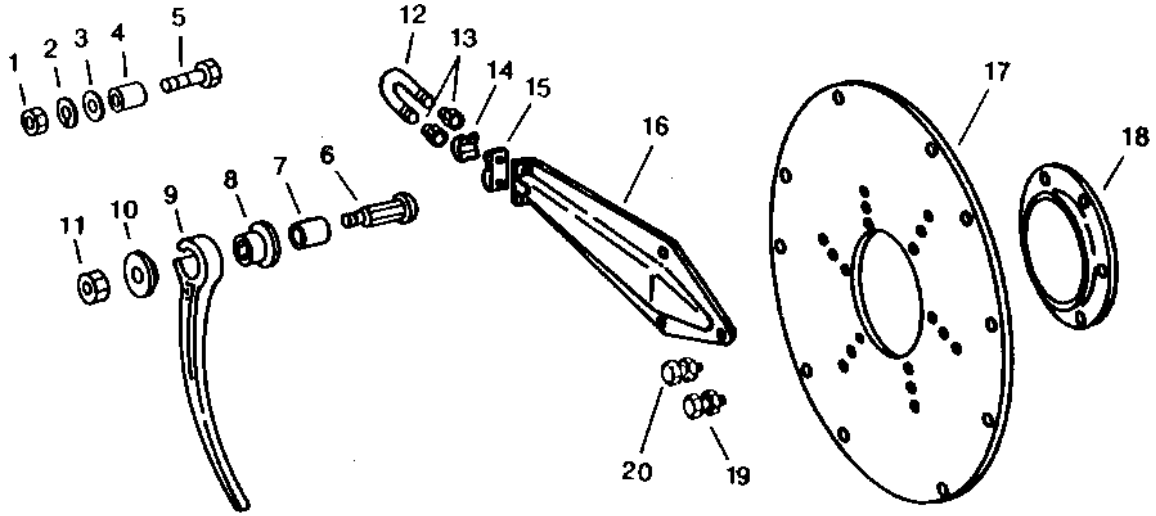

HP4952

KEY	PART NO.	PART NAME	QTY	SERIAL NO.	REMARKS
1	14H1040	NUT	1		1/2", (FLEX)
2	12H301	LOCK WASHER	1		1/2", (FLEX)
3	24H1162	WASHER	1		17/32" X 1-1/4" X 0.060", (FLEX)
4	H89200	SPACER	6		(FLEX)
5	19H1831	CAP SCREW	1		1/2" X 2", (FLEX)
6	E59585	BOLT	6		(RIGID)
7	E40212	SPACER	6		(RIGID)
8	H132149	BRACKET	6		(RIGID)
9	H132147	FINGER	6		(RIGID)
10	H132148	RETAINER	6		(RIGID)
11	E59584	FLANGE NUT	6		12.700 MM (1/2") FLANGE (RIGID)
12	E40203	U-BOLT	6		
13	E45229	LOCK NUT	12		6.350 MM (1/4")
14	E40205	CAP	6		
15	E40206	BASE	6		
16	AH97207	ARM	6		
17	H98691	PLATE	1		
18	H98693	RING	1		
19	19H2020	CAP SCREW	12		5/16" X 1/2"
	12M7065	LOCK WASHER	12		8.100 MM (0.319")
	14H785	NUT	12		5/16"
20	19H1900	CAP SCREW	6		5/16" X 3/4"
	12M7065	LOCK WASHER	6		8.100 MM (0.319")
	14H785	NUT	6		5/16"

NOTE: QUANTITIES SHOWN ARE FOR ONE END ONLY.

BH77217 (COMPLETE GOODS) SPIDER ASSEMBLY - 20,22,24,25,30'

A20

REEL

PICKUP REEL DRIVE, R.H. MOUNTINGS AND GEARS (-645300)
 HP2873 -UN-01JAN94

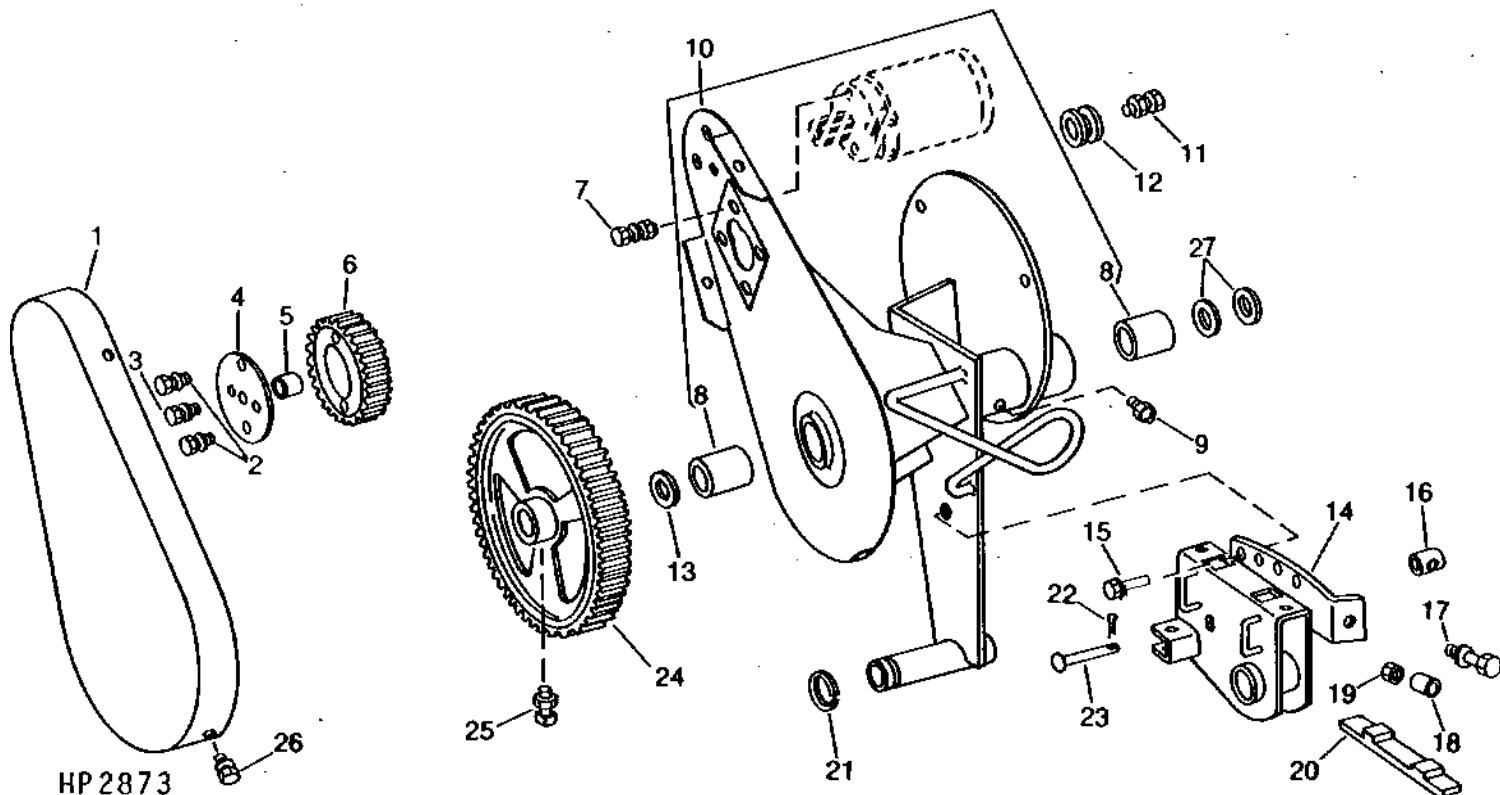

KEY	PART NO.	PART NAME	QTY	SERIAL NO.	REMARKS
1	H128688	SHIELD	1		DRIVE REEL
2	19H2020	CAP SCREW	2		5/16" X 1/2"
	12M7065	LOCK WASHER	2		8.100 MM
3	19H1875	CAP SCREW	1		5/16" X 1-3/4"
	12M7065	LOCK WASHER	1		8.100 MM
4	H130270	PLATE	1		
5	H130269	SPACER	1		
6	H129436	PINION	1		18 TEETH
7	19H1936	CAP SCREW	4		3/8" X 3/4"
	12H304	LOCK WASHER	4		3/8"
	24H1305	WASHER	4		13/32" X 13/16" X 0.065"
8	H98743	BUSHING	2		
9	JD7759	LUBRICATION FITTING	1		STRAIGHT, 1/8"
10	AH125780	SUPPORT	1		R.H.
11	19H1765	CAP SCREW	3		3/8" X 1-3/4"
	12H304	LOCK WASHER	3		3/8"
	14H812	NUT	3		3/8"
12	AE24403	BALL BEARING	3		
13	24H1509	WASHER	1		1-25/64" X 2-1/2" X 0.194"
14	AH124042	SUPPORT	1		R.H.
15	E57351	SELF-LOCKING SCREW	1		
16	H89110	TRUNNION	1		
17	08H4654	CAP SCREW	1		1/2" X 7-1/2"
	24H1111	WASHER	1		17/32" X 1-1/16" X 0.090"
18	H81277	BUSHING	1		
19	E54809	LOCK NUT	1		
20	H120584	PAD	1		REEL SLIDE
21	C3142E	SNAP RING	1		
22	11M7017	COTTER PIN	1		3.200 X 32 MM
23	Q1146M	PIN	1		
24	H121675	SPUR GEAR	1		(SUB AH139288) DRIVEN, 73 TEETH
25	22H836	SET SCREW	2		3/8" X 1"
	14H732	NUT	2		3/8"
26	H78354	SCREW	3		(SUB H78354)
27	24H1929	WASHER	2		1.620" X 2-1/4" X 0.120"